



50/60 Hz

FOCCETA

RESIDENTIAL ROOF FAN > FOCCETA

www.casals.com

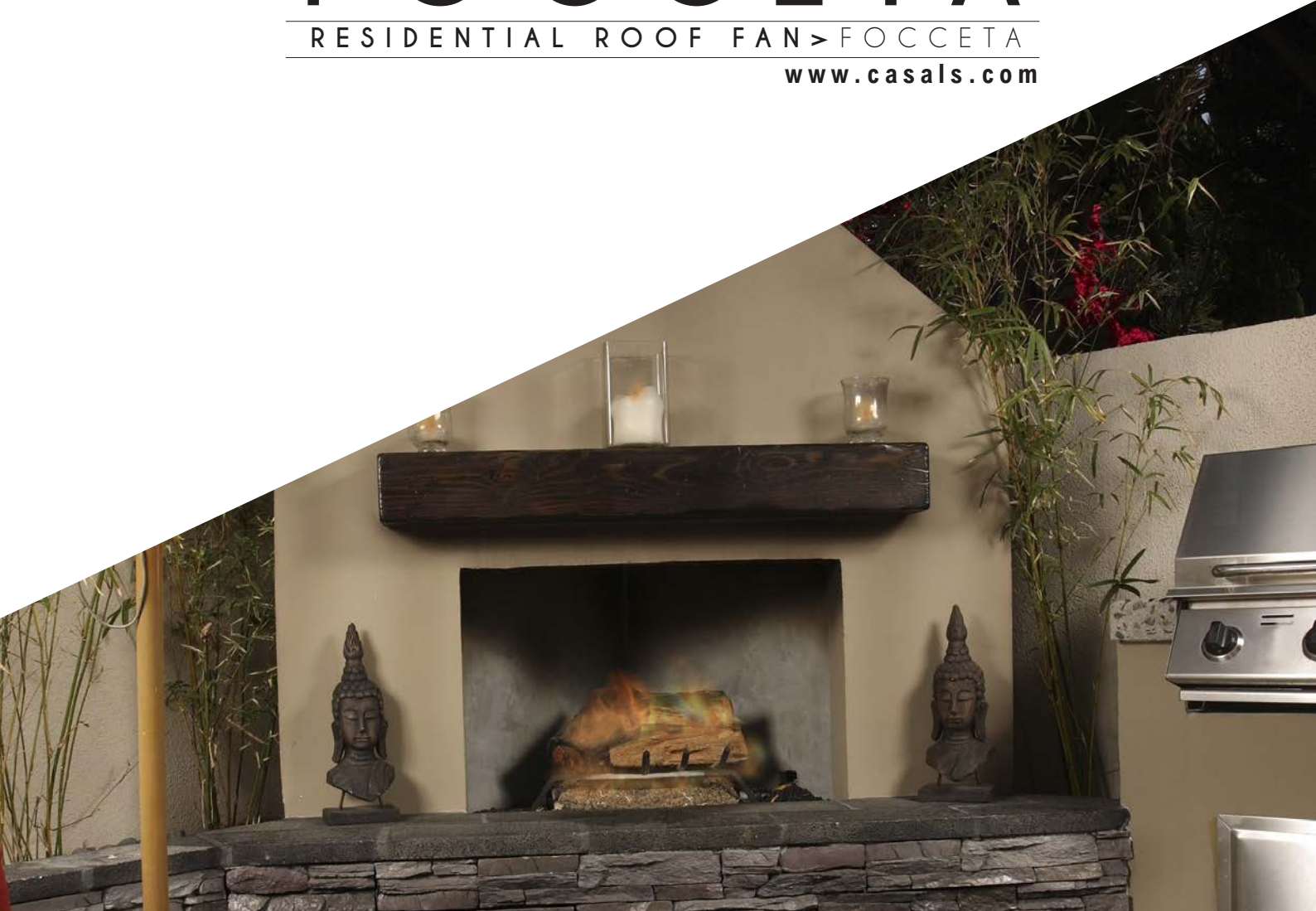

FOC CETA

> ADVANTAGES

- ✓ Fan for extraction of chimneys and barbecues.
- ✓ To operate at elevated temperatures (of the order of 200 °C) continuously.
- ✓ Suitable structure to stay outdoors and anticorrosive treatment.
- ✓ Compact and attractive design.

> THE SMOKE EXTRACTOR FOR CHIMNEYS <



CENTRIFUGAL ROOF FAN FOR FIREPLACES AND BARBECUES

> MANUFACTURING FEATURES

- ✓ Steel motor cover with hammered texture. Polyester powder coated in black colour
- ✓ Asynchronous motor with thermal overload cutout and shaft turning in ball bearings. Standard voltage 230V at 50/60Hz, IP X4 an I class.
- ✓ Backward curved impeller with dynamically balanced self-cleaning aluminium blades (UNI ISO 1940, Point 1 – Class 6.3).
- ✓ Protection grille with anti-bird rings (in accordance with UNI ISO 13857 standard), made of electrically welded steel; epoxy paint finish, colour black.
- ✓ Base manufactured from phosphated pressed steel, epoxy powder coated with hammered effect finish, guaranteeing long-term resistance to atmospheric agents.
- ✓ Aerodynamically contoured inlet port for optimum performance, fashioned as a single unit with the base and gauged to optimize air flow.
- ✓ Sub-frame for fixing the appliance to the flue stack.
- ✓ Equipped with steel safety wire for anchoring the appliance once installed.

> APPLICATIONS

- ✓ Specially designed for smoke extraction use at a continuous operating temperature up to 200 °C in fireplaces and barbecues.

> DIMENSIONS

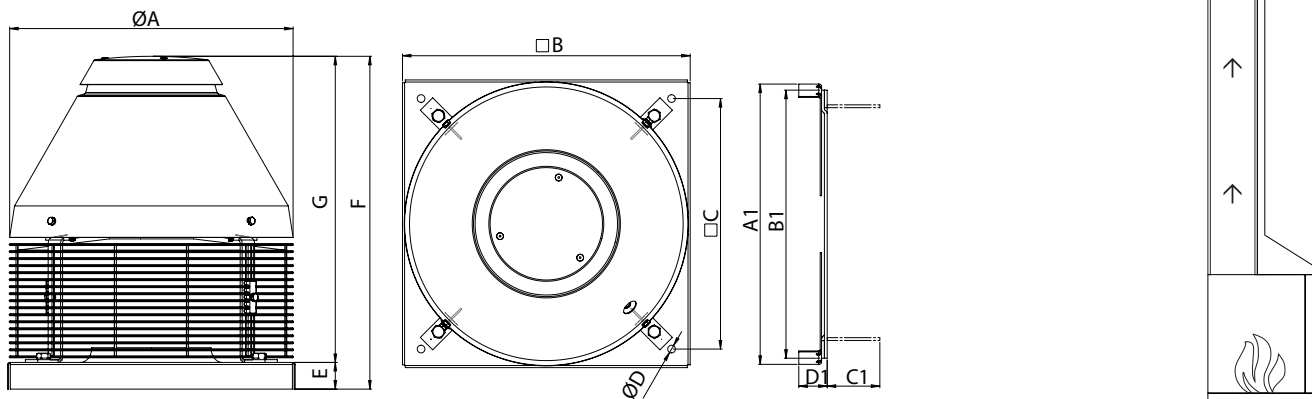

MODEL	ØA	A1	B	B1	C	C1	ØD	D1	E	F	G
FOC CETA	405	401	410	357	357	140	10	40	38	518	480